

Header Installation Instructions with EML 310/320 and 371/372

For 4-1/8", 4-1/2", 6" Headers

For use with DRS Rails and Patch Fittings

Installation instructions

933903 – 07-2019

| EN |

dormakaba 

Table of contents

1	Technical specifications	3	4	Install armature plate	14
1.1	RTS88 and PT21 Header		4.1	(For use with patch fittings only)	
	Specification Overview	3		secure glass door bracket (GDB)	14
	1.1.1 General information	3	4.2	(For use with DRS rails only)	15
	1.1.2 Glass requirements/fittings/mounting	3			
	1.1.3 Requirements for glass panel	3	5	EML310/320 and 371/372 Options	16
	1.1.4 Safety instructions	3	5.1	Instant release of lock	16
	1.1.5 Symbols used - Safety/Installation	3	5.2	Lock monitoring options - BA - Bond Alert Sensor	16
	1.1.6 Maintenance, care, repair	3	5.3	Lock monitoring options - DP - Door Position Sensor	16
	1.1.7 Disposal	3			
1.2	EML310 and EML320 Specifications Overview	4	6	Wiring the EML	17
	1.1.1 General information	4	6.1	Wiring mag lock body through header (for EML310/320 and 371/372)	17
	1.1.2 Listings	4	6.2	Wiring mag lock body (for EML310/320) - continued	18
	1.1.3 Conditions of acceptability	4	6.3	Wiring for BA or BA DP combination models (for EML371/372)	19
	1.1.4 EML310/320 Mechanical specifications: (Including 1/4" [6.4] mounting bracket)	4	6.4	Wiring for Unmonitored or DP sensor models (for EML371/372)	19
	1.1.5 EML371/372 Mechanical specifications: (Including 3/16" [4.8] mounting bracket)	5			
	1.1.6 Environmental specifications:	5	7	EML310/320 and 371/372 trouble shooting guide	20
	1.1.7 EML310/320 Electrical specifications:	5			
	1.1.8 EML371/372 Electrical specifications:	5			
	1.1.9 Inspection and Maintenance	5			
1.3	EML header options	6			
1.4	Pin diameter specifications	7			
2	RTS88 and PT21 installation instructions	8			
2.1	Install header for single or double door: RTS88	8			
2.2	Install header for single or double door: PT21	9			
2.3	RTS88 adjustments	10			
2.4	PT21 adjustments	10			
3	EML and shim installation instructions	11			
3.1	Prepare/disassemble mag lock body and mounting plate	11			
3.2	Secure header shim to frame/ceiling surface (for 4-1/8" or 4-1/2" headers only)	11			
3.3	Secure mounting bracket and mag lock to shim (for 4-1/8" or 4-1/2" headers only)	12			
3.4	Secure mounting bracket and mag lock to shim (for 6" headers only)	13			

1 Technical specifications

1.1 RTS88 and PT21 Header Specification Overview

These instructions are for installation of the EML 310/320 and 371/372, EML Header Shim, with RTS88 and PT21 Headers for the following ceiling mounting.

1.1.1 General information

- dormakaba requires use of tempered monolithic or tempered laminated glass.
- dormakaba glass hardware is not suitable for harsh environment; for example, applications where chemicals (e.g. chlorine) are used such as indoor swimming pools, saunas, or salt-water pools.
- Do not swing doors with excessive force. Install limiting stop to prevent door from opening too far.

1.1.2 Glass requirements/fittings/mounting

- The substructure/wall must be able to bear permanent loads, and be level (max. tolerance: 1/16" [2] per 39" [1m]).
- Fasteners must be sufficiently dimensioned for the substructure/wall and weight of the door.
- When adjusting glass elements, always stick to the required clearance for the respective hardware. Adjust clearance so glass does not come in contact with any hard surfaces such as glass, metal or concrete.
- Do not use excessive force when installing the glass (avoid over tightening screws.)

1.1.3 Requirements for glass panel

- dormakaba requires use of fully tempered glass, which complies with ASTM C 1036 and ASTM C 1048. Secondary heat soaking processes are optional but not required.
- Clamping area must be flat and uncoated (no self-cleaning coating!)
- Never use glass with conchoidal fractures and/or damaged edges.

1.1.4 Safety instructions

- Installation requires two people.
- Always wear protective clothing.
- Only properly qualified and specially trained staff are authorized to mount dormakaba glass hardware.
- Due to crushing hazards and possible injury caused by breakage of glass during mounting, corresponding protective clothing (especially gloves and protective goggles) is required.
- Never clamp metal fitting hardware directly to glass surface.

1.1.5 Symbols used - Safety/Installation



CAUTION

Mounting components must meet the requirements of substructure/wall and door weight. Please read the technical information for fittings.



WARNING

Risk of breaking glass. When installing the door, support the door panel with a block of wood or similar object.



TIPS AND RECOMMENDATIONS

Universal PT21 pin diameter: 5/8" [15]
MUNDUS PT21 pin diameter: 9/16" [14]

1.1.6 Maintenance, care, repair

- Immediately replace damaged parts.
- Always use original dormakaba parts.
- Clean clamping area with alcohol-based standard commercial cleaning agent before mounting the glass hardware.
- Use a damp cloth for occasional cleaning.
- Always use silicone - and oil-free cleaners (e.g. acetone).
- Check glass hardware at regular intervals for proper positioning, smooth operation and correct adjustment.
- High traffic door systems require inspection by properly qualified staff (specialized companies or installation firms.)

1.1.7 Disposal

Disposal in accordance with local, state and national regulations.

1.2 EML310/320 and EML371/372 Specifications Overview

1.1.1 General information

- This product must be installed according to all applicable building and life safety codes.
- Due to the variety of mounting configurations available with this product, a survey and assessment of the physical area in which the product will be installed must be performed.
- This door frame must be inspected and deemed structurally sound prior to installation of the electromagnetic lock. The structural integrity of the mounting surfaces must be strong enough to meet or exceed the holding force of the product.
- The product must be protected from potential damage due to intruders or tampering.
- The product should be installed in a location that will not hinder or create a potential safety hazard to authorized personnel accessing the protected area.
- Because electromagnetic locks are used in a variety of applications and different door frame configurations, an experienced installer with knowledge of this product must make a determination of the optimal mounting method for this specific application.
- The components, hardware, installation instructions and mounting template included with this product are intended for use on outswinging doors.
- Do not install this product on the exterior of a building.
- Do not use as a doorstop. This will void the warranty.
- Separate accessories not included with this product must be used in the following applications:
 - » Inswinging doors
 - » Narrow head jamb situations or center-hung doors
 - » Wherever there is insufficient space on the door frame header to mount the lock
 - » Hollow metal or wood frames where the door stop is not thick enough to allow the product to be installed
 - » Wherever an obstruction in the door prevents installation of the armature plate at the proper height
 - » Doors that do not permit the armature plate to be mounted low enough to meet the magnet surface.
- Installation of this product should be done by an experienced installer with knowledge of this product.
- NOTE: It is highly recommended that thread locking compound be applied to all screws during installation to reduce chance of screws loosening over extended time.

1.1.2 Listings

- These products have been successfully tested and evaluated by UL in two separate categories for use in both the United States and Canada.
- *Auxiliary Lock* - The GWXT fire listing qualifies these for use with UL Classified fire doors maximum 4' [1219] in width and 8' [2438] in height rated up to and including 1 hour.
- *Special Locking Arrangement Component* - Additionally, these products are qualified components for the purpose of locking outward-swinging exit doors against unauthorized egress. They are designed to release automatically in case of a power failure or upon activation of an automatic fire alarm system wired to the power supply fire panel relay.

1.1.3 Conditions of acceptability

- This product is intended for use with Special Locking Arrangements which are installed in accordance with the manufacturer's installation and operation instructions, the Life Safety Code, NFPA 101 of the National Fire Protection Association, and the local authority having jurisdiction.
- The power for this unit is to be provided by a Listed (ALVY, ALVY7, FULA, FULA7, FUPPC, UEHX7, APHV or APHV7) Class 2 power supply when designated as a Special Locking Arrangement (FWAX or FWAX7).
- The suitability of the lead wires is to be evaluated per the requirements for the end-use product.
- When this product is installed in conjunction with a fire alarm control panel, the wiring from the control unit to this product device shall be for fail-safe operation.
- For Canadian installations, this product is to be installed in accordance with the manufacturer's installation and operation instructions, The Canadian Electrical Code C22, 1-02, and the local authority having jurisdiction.
- To qualify for use in a delayed-egress locking system, the relock delay must be set to 0 seconds.
- UL testing was conducted on standard model without accessories. These locks are not intended or tested for use as a UL Listed Buglar Alarm System Unit.
- These models have also been independently tested to the ANSI/BHMA A156.23-2010 American National Standard for Electromechanical Locks.
 - *Holding Force*: 1500 lbf
 - *Cycle Test*: Grade 1 = 1 million cycles

**1.1.4 EML310/320 Mechanical specifications:
 (Including 1/4" [6.4] mounting bracket)**

- *EML310 Lock dimensions:*
 1-5/8"D x 2-7/8"W x 10-1/2"L [41 x 73 x 268]
- *EML320 Lock dimensions:*
 1-5/8"D x 2-7/8"W x 21-1/8"L [41 x 73 x 536]
- *Standard armature plate dimensions:*
 5/8"D x 2-3/8"W x 7-7/16"L [16 x 61 x 190]
- *DP armature plate:*
 9-3/4"L [247]

**1.1.5 EML371/372 Mechanical specifications:
 (Including 3/16" [4.8] mounting bracket)**

- *EML371 Lock dimensions:*
 1"D x 1-7/8"W x 9-3/8"L [25 x 47.6 x 238]
- *EML372 Lock dimensions:*
 1"D x 1-7/8"W x 18-3/4"L [25 x 47.6 x 476]
- *Armature plate dimensions:*
 7/16"D x 1-1/2"W x 7-1/4"L [11 x 38 x 184]

1.1.6 Environmental specifications:

- Not for use in outdoor environments.
- Circuit board operating temperature: 14° to 140°F [-10° to 60°C]

1.1.7 EML310/320 Electrical specifications:

- *BA Output Relay* Δ : SPDT relay. Contacts rated at 1.25A @ 24VDC.
- *DP Reed Switch* Δ : Magnetically actuated SPDT switch. Contacts rated for 0.20A @ 12VDC and 0.12A @ 24VDC.

**Δ Effective for either resistive or inductive loads
 (power factor ≥ 0.6 with inductive loads.)**

NOTE: Specification may change without notice.

1.1.8 EML371/372 Electrical specifications:

- *SCS Output Relay*: SPDT relay. Contacts rated at 1.0A at 24VDC.
- *DSS Reed Switch*: Magnetically actuated SPDT switch. Contacts rated for 0.20A @ 12VDC and 0.12A @ 24VDC.

NOTE: Specification may change without notice.

Power Supply:

Voltage	EML310	EML320	EML371	EML372
12VDC	0.65A	0.65A x 2 = 1.30A	0.52A	0.52A x 2 = 1.04A
24VDC	0.45A	0.45A x 2 = 0.90A	0.26A	0.26A x 2 = 0.52A

NOTE: All dormakaba electromagnetic locks must be powered with a Listed filtered and regulated DC power supplies such as the dormakaba PS Series UL Listed Power Supply. dormakaba offers a full line of power supplies and switching devices that are suitable for use with the EML310/EML320 locks and EML371/EML372 locks.

1.1.9 Inspection and Maintenance

- This product and all related accessories or parts must be inspected and maintained on a quarterly basis. Contacting surfaces of the electromagnetic lock and armature plate must be kept free of contaminating materials. Surfaces must be cleaned periodically with a non-abrasive cleaner.
- All mounting fasteners must be inspected on a quarterly basis. When properly installed, the ends of the armature plate allow slight movement but the plate will feel secure when grasped at the bolt. There should be no movement to the mounting bracket or housing of the electromagnetic lock.
- For added safety, thread locking compound has been provided for the armature plate bolt and the four captive electromagnetic lock mounting screws.
- **WARNING:** Improper installation, maintenance, inspection or usage of the product or any related accessories or parts may cause the electromagnetic lock mounting screws to fail.
- dormakaba will not be liable to the installer, purchaser, end user or anyone else for damage or injury to person or property due to improper installation, care, storage, handling, maintenance, inspection, abuse, misuse or act of God or nature involving this product or any related accessories or parts.

1.3 EML header options

Fig. 1

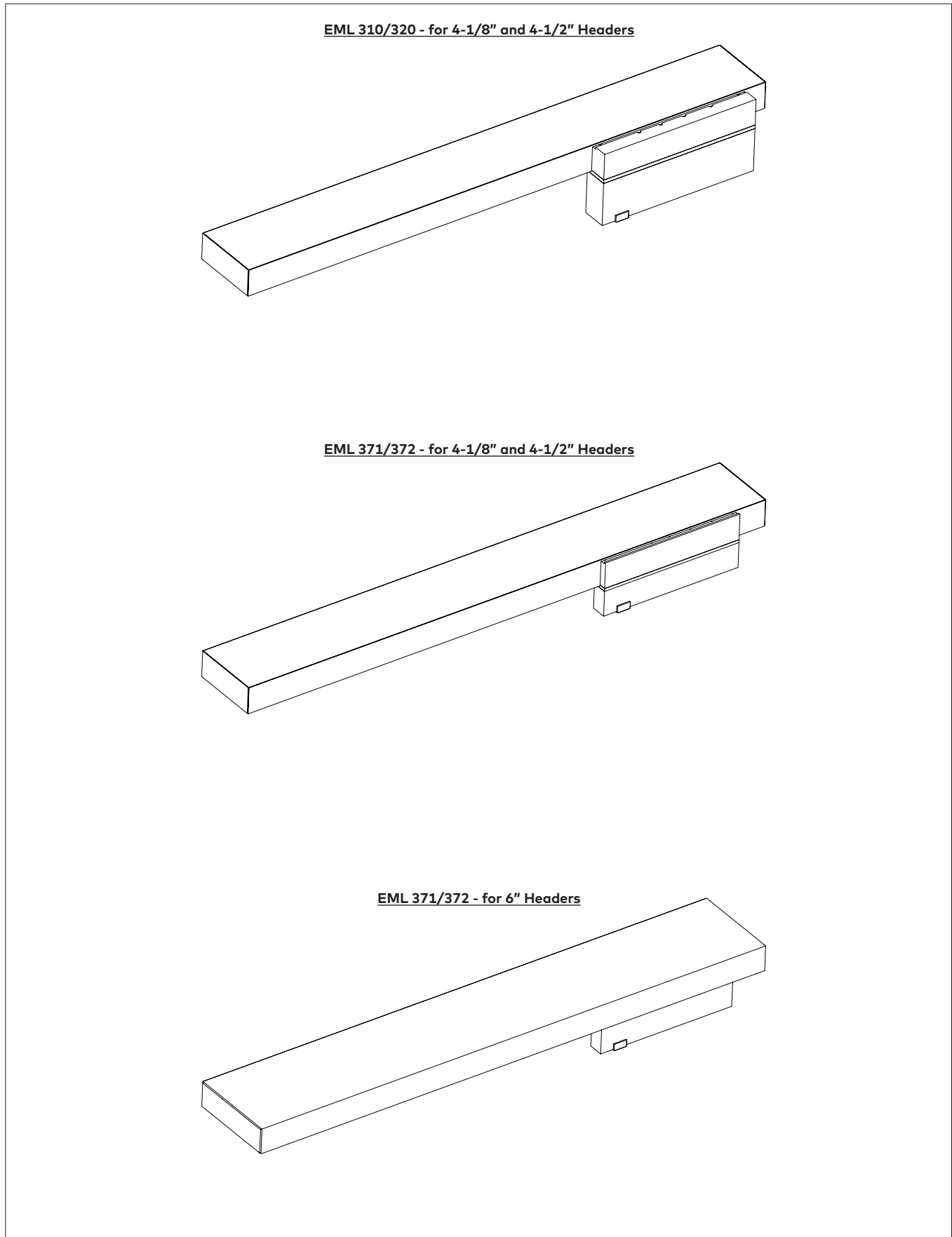

1.4 Pin diameter specifications

Fig. 2

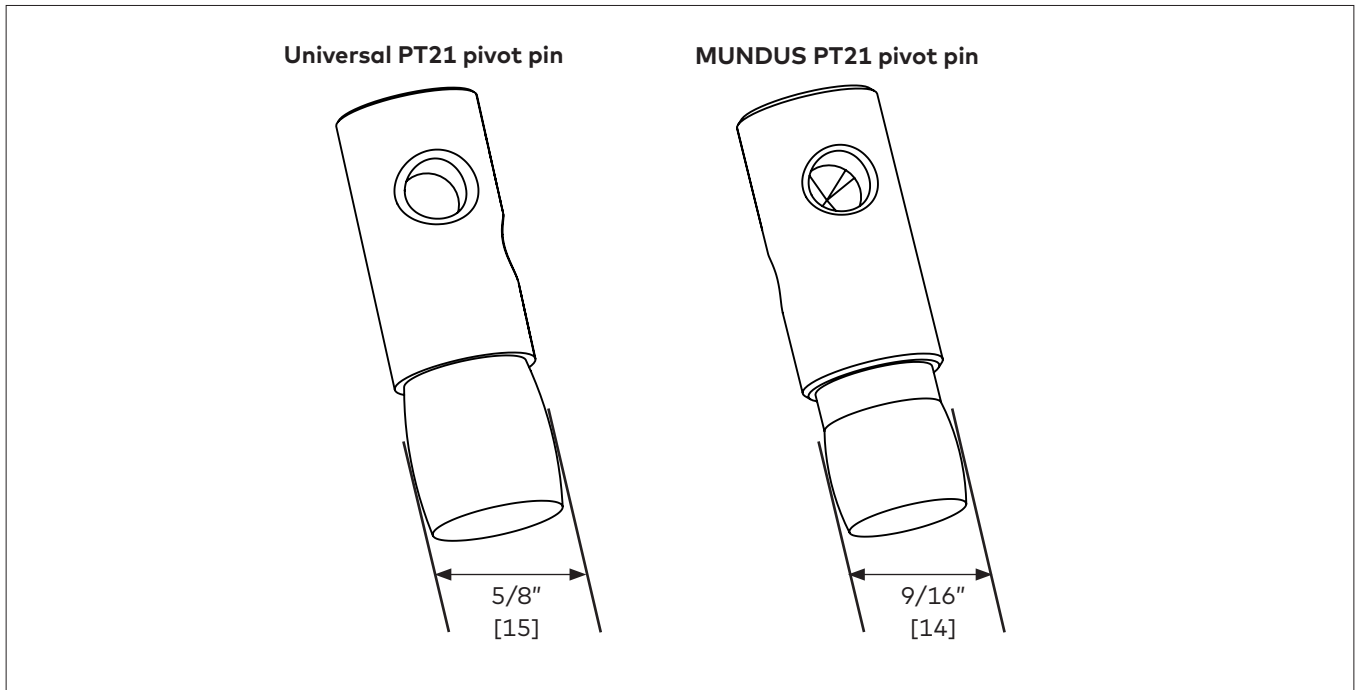

2 RTS88 and PT21 installation instructions

2.1 Install RTS88 header for single or double door

Fig. 3

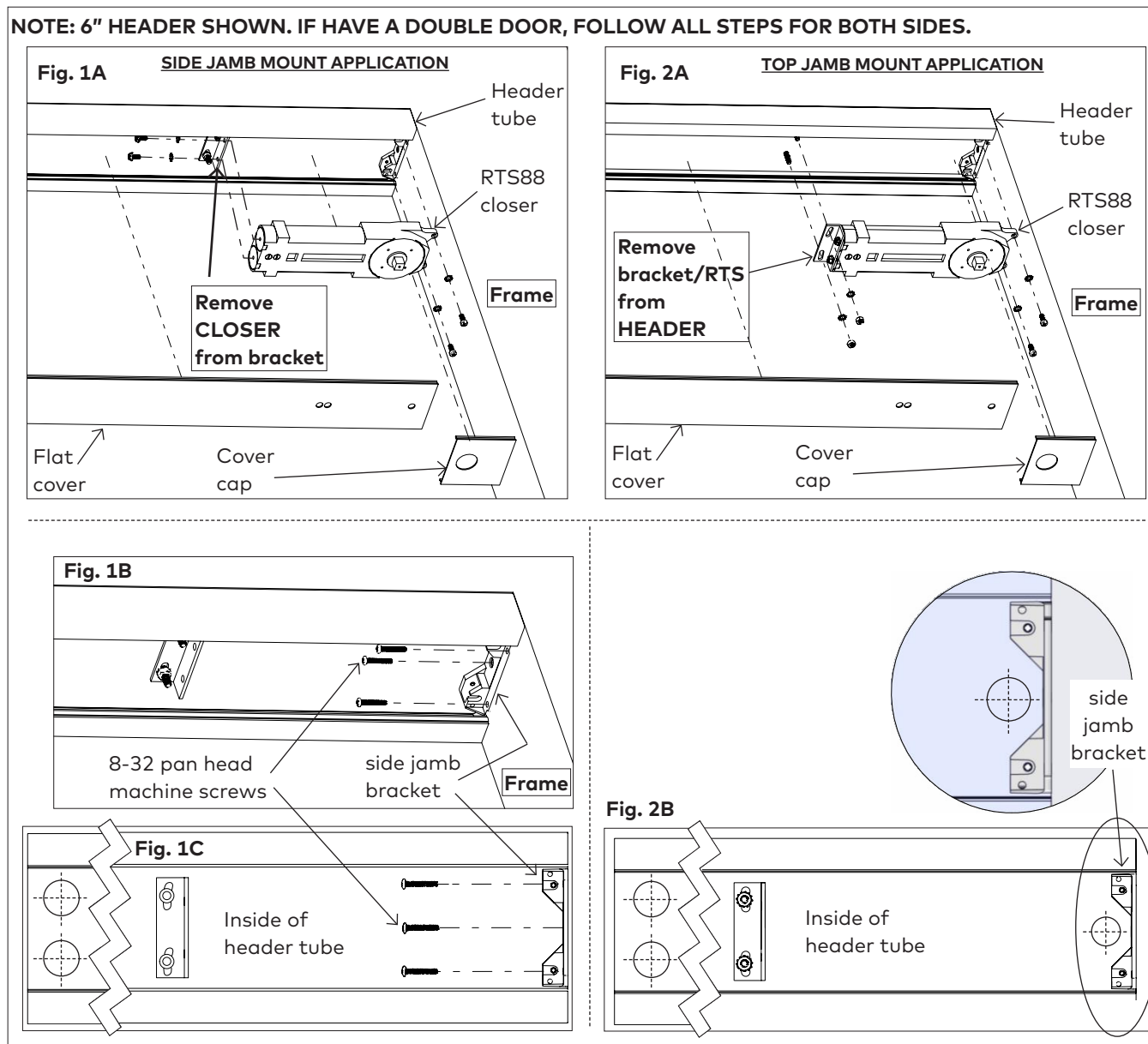

2.1.1 Remove covers and RTS closer from header tube.

Determine proper mounting: top jamb or side jamb. Reference Figures 1A & 2A.

2.1.2 Pre-drill holes and secure header tube using appropriate fasteners dependent upon application: side jamb or top jamb mount:

2.1.2.1 **Side jamb mount:**

- Secure side jamb bracket to frame using three 8-32 pan head machine screws [#10 pan head wood screws]. Figures 1B & 1C.
- And secure header to overhead frame using appropriate fasteners. Figure 1C.

2.1.2.2 **Top jamb mount:** Figure 2B.

- Secure header to overhead frame **only**, using appropriate fasteners.

NOTE: Always ensure the proper fasteners and adequate number of fixing points for your specific field conditions.

2.1.3 Resecure RTS88 closer inside header tube using included fasteners.

2.1.4 Adjust closer if necessary. See adjustments section: 2.3

2.1.5 Snap cover cap and flat cover back into place.

2.1.6 For double door applications, follow steps 2.1.1 through 2.1.5.

NOTE: (IF NECESSARY) ENSURE HOLES ARE CUT INTO HEADER FOR FEEDING WIRES THROUGH.

2.2 Install PT21 header for single or double door

Fig. 4

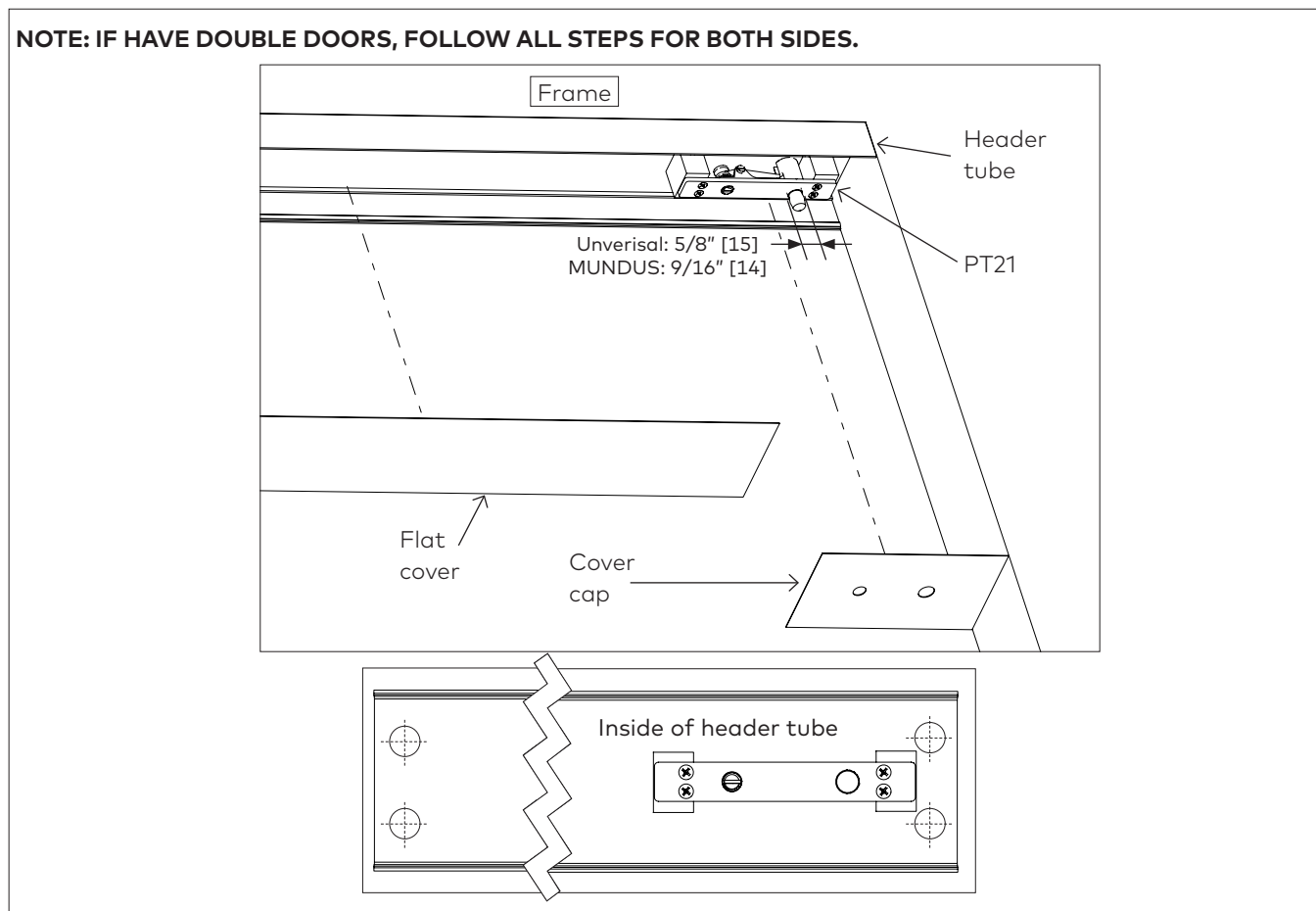

- 2.2.1 Remove covers from header tube.
- 2.2.2 Pre-drill holes in header tube for installation.
- 2.2.3 Secure header tube to overhead frame using appropriate fasteners dependent upon application.

NOTE: Always ensure the proper fasteners and adequate number of fixing points for your specific field conditions.

- 2.2.4 Adjust PT21 if necessary: See adjustment section: 2.4
- 2.2.5 Snap cover cap and flat cover back into place.
- 2.2.6 For double door applications, follow steps 2.1.1 through 2.1.4.

NOTE: (IF NECESSARY) ENSURE HOLES ARE CUT INTO HEADER FOR FEEDING WIRES THROUGH.

2.3 RTS88 adjustments

Fig. 5

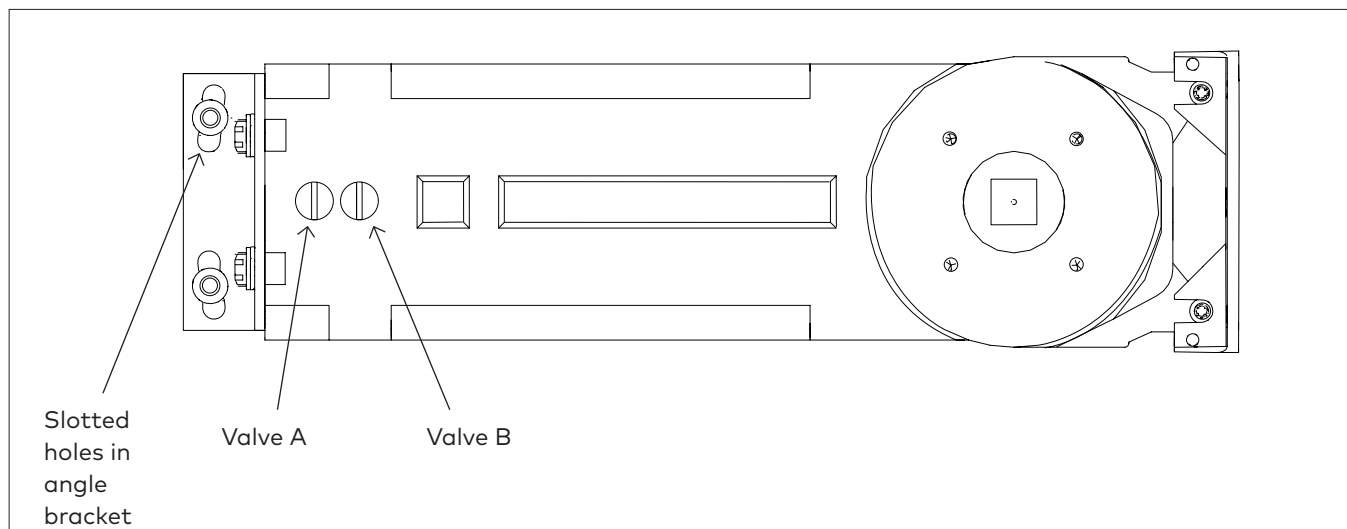

2.3.1 Ensure RTS is plumb and level.

2.3.2 Adjust via slotted holes in angle bracket prior to fully tightening screws.

- Valve "A" - Closing/sweep speed - from maximum opening to 0°.
Clockwise - decrease closing speed
Counter-clockwise - increase closing speed
- Valve "B" - Latch speed - from maximum opening to 20°.
Clockwise - decrease closing speed
Counter-clockwise - increase closing speed

2.4 PT21 adjustments

Fig. 6

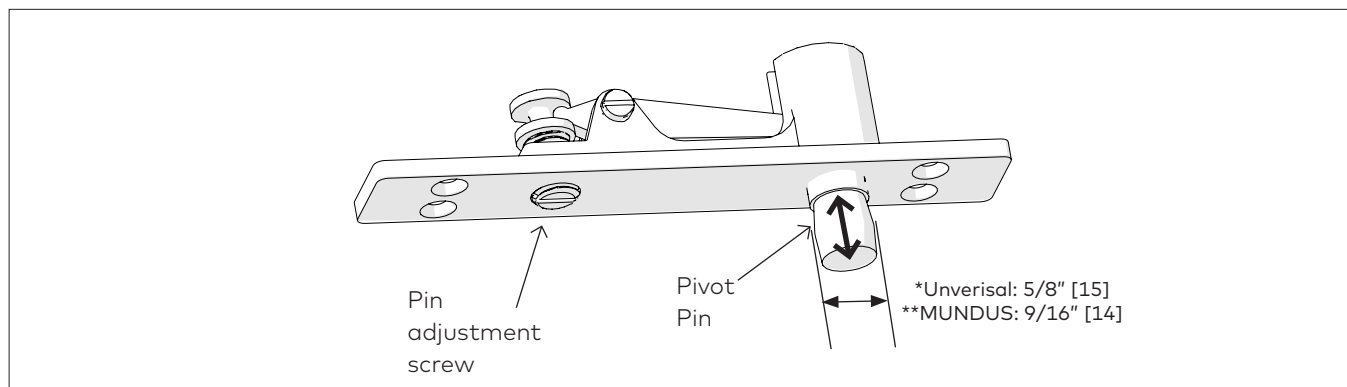

2.4.1 Ensure PT21 is plumb and level.

2.4.2 Raise pivot pin up completely by rotating pin adjustment screw.

2.4.3 Lower pin once door is properly in place.

3 EML and shim installation instructions

3.1 Prepare/disassemble mag lock body and mounting bracket

Fig. 7

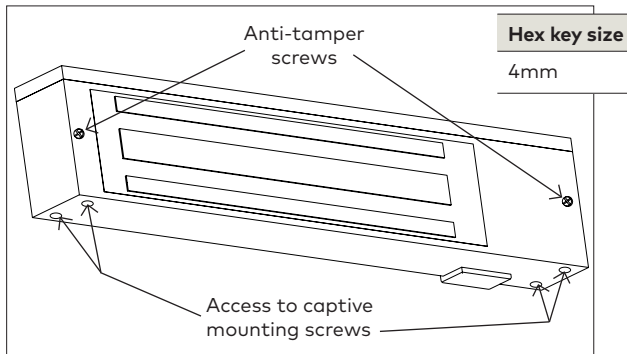

3.1.1 Remove anti-tamper screws to access captive mounting screws.

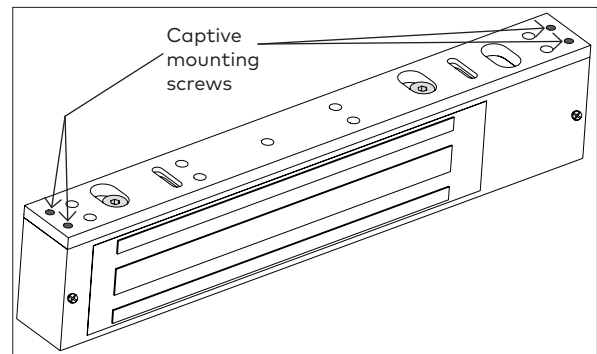

3.1.2 Unthread captive mounting screws from bottom.

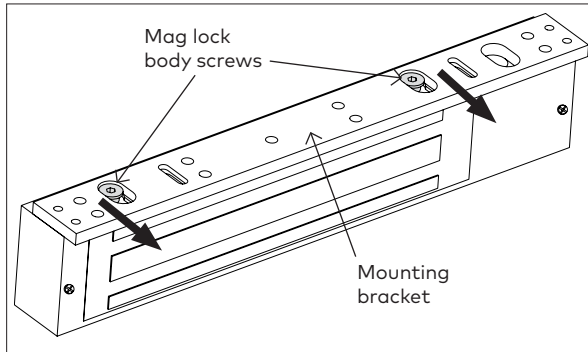

3.1.3 Slide and lift mounting bracket from mag lock body screws.

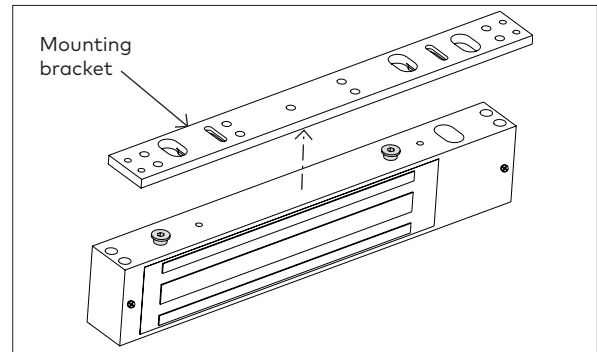

NOTE: DO NOT REMOVE OR LOOSEN MAG LOCK BODY SCREWS.

3.2 Secure header shim to frame/ceiling surface (for 4-1/8" or 4-1/2" headers only)

Fig. 8

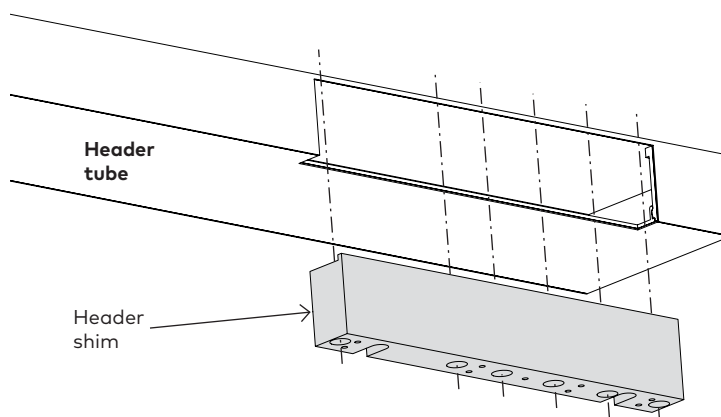

3.2.1 Secure header shim to frame above or ceiling surface using appropriate fasteners.

NOTE: May need to drill through header tube depending on shim hole locations.

EML 371/372 header shim shown.

Same instructions to be used for EML 310/320.

3.3 Secure mounting bracket and mag lock to shim (for 4-1/8" or 4-1/2" headers only)

Fig. 9

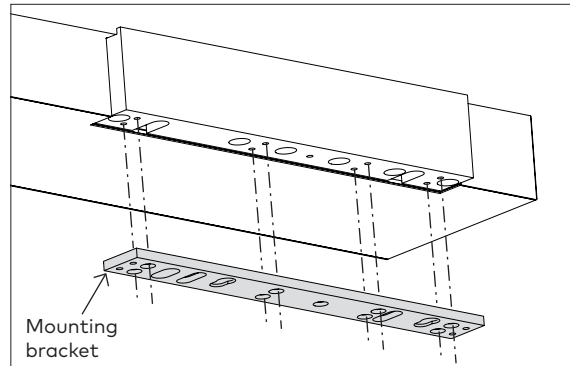

3.3.1 Secure mounting bracket to shim with appropriate fasteners.

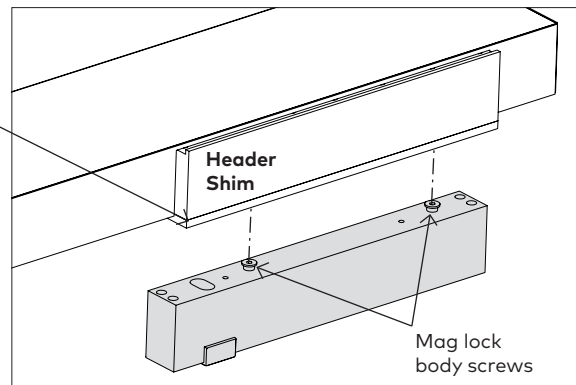
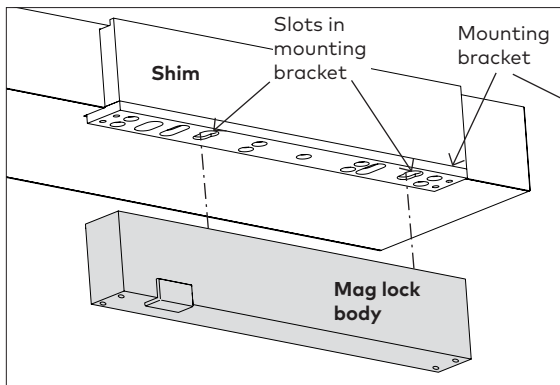

3.3.2 Secure mag lock body to mounting bracket.

- Insert mag lock body screws into slots in mounting bracket.

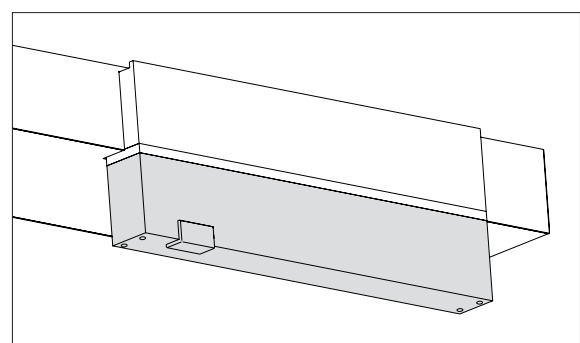
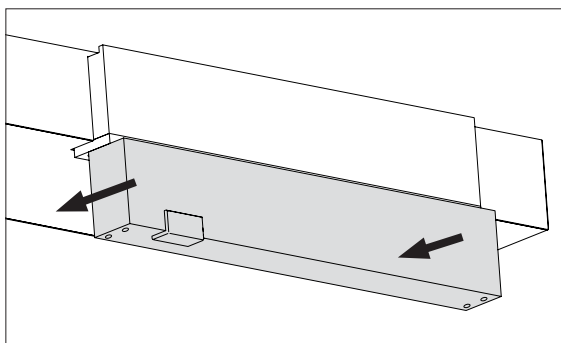

3.3.3 Slide mag lock body backward and into place in slots.

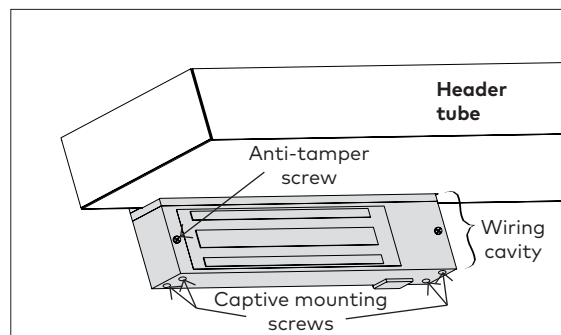

3.3.4 Rethread captive mounting screws.

3.3.5 Reinsert one (1) anti-tamper screw.

NOTE: Other anti-tamper screw to reinsert later. Access needed to wiring cavity.

Hex key size

4mm

3.4 Secure mounting bracket and mag lock to shim (for 6" headers only)

Fig. 10

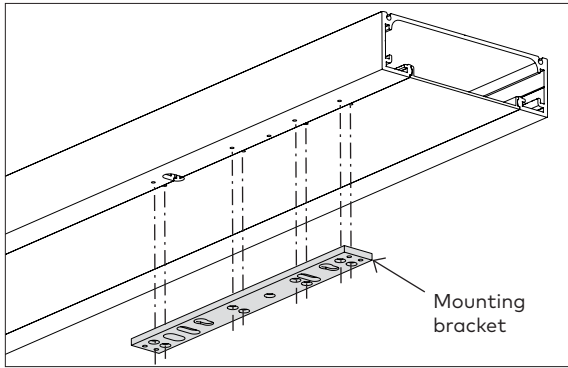

3.4.1 Secure mounting bracket to shim (pre-installed inside header tube) with appropriate fasteners.

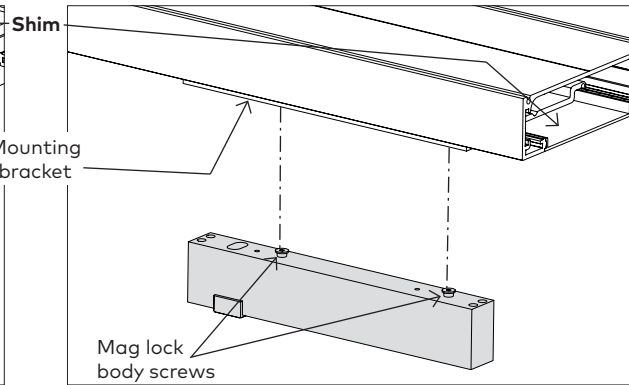
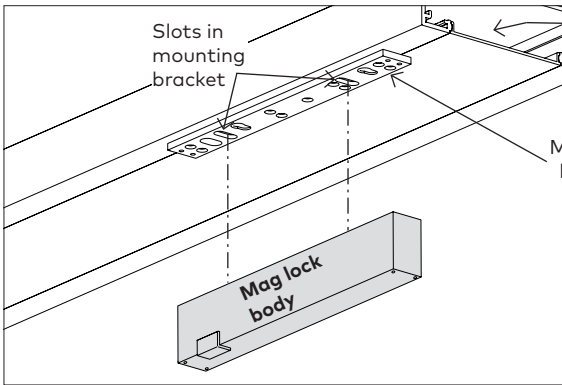
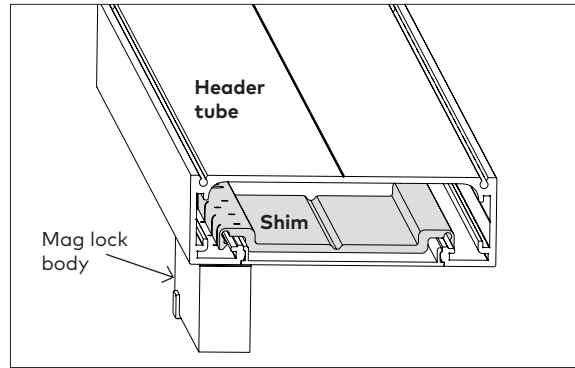

3.4.2 Secure mag lock body to mounting bracket.
 • Insert mag lock body screws into slots in mounting bracket.

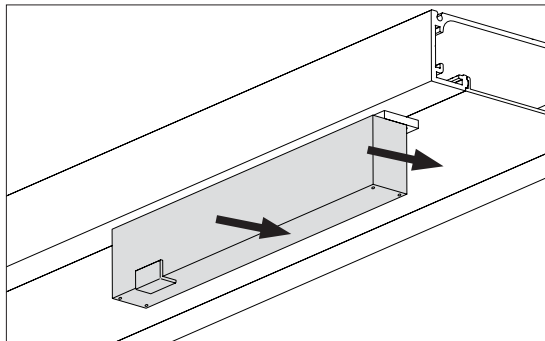

3.4.3 Slide mag lock body backward and into place in slots.

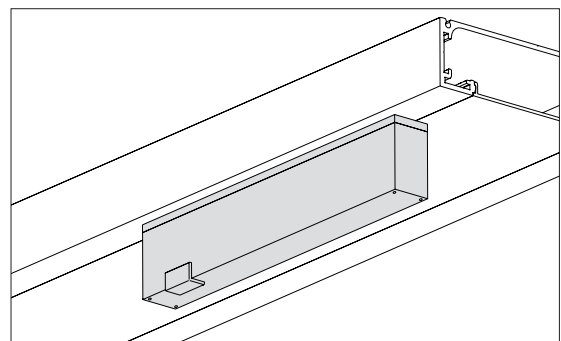

3.4.4 Rethread captive mounting screws.

3.4.5 Reinsert one (1) anti-tamper screw.

NOTE: Other anti-tamper screw to reinsert later. Access needed to wiring cavity.

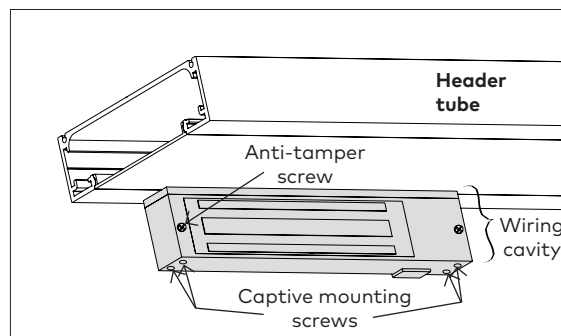

Hex key size

4mm

4 Install armature plate

4.1 (For use with patch fittings only) secure glass door bracket (GDB)

Fig. 11

NOTE: Armature plate should remain movable. See step 4.1.9 on this page.

NOTE: Armature plate must be allowed to pivot on the center-mounting bolt to allow proper alignment with the magnet surface. If not properly aligned with the magnet surface, the lock may lose holding force or not lock at all.

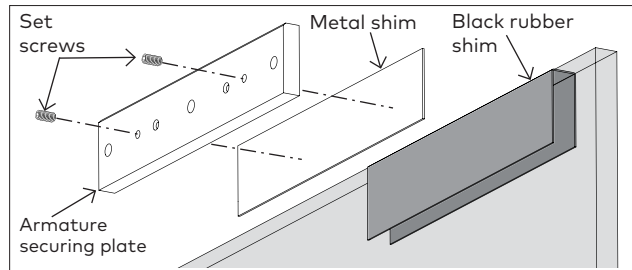
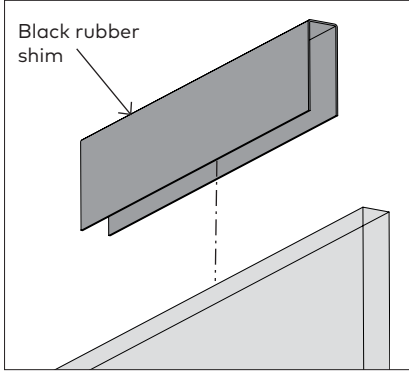

4.1.1 Temporarily and gently secure (hand-tighten) the following glass door bracket parts to the glass panel:

- Black rubber shim
- Metal shim
- Armature securing plate

4.1.2 Gently secure with included set screws.

NOTE: The head of the armature mounting bolt ships with a rubber washer affixed to it. Ensure this washer projects slightly beyond the surface of the armature plate. This is to allow the washer to expand when power is removed and break the air vacuum between the plate and the magnet surface. **DO NOT REMOVE OR TRIM THE WASHER.** This will cause the lock to continually have some holding force even when power is removed.

NOTE: Allow left-to-right movement of glass door bracket assembly so it can be properly aligned with mag lock.

4.1.3 Close door to align mag lock and glass door bracket assembly. Adjust bracket left or right if necessary.

4.1.4 Mark glass door bracket location on door.

4.1.5 Fully tighten set screws.

4.1.6 Slide U-shaped bracket cover over top of assembly.

4.1.7 Fully secure with included fasteners.

4.1.8 Align armature plate via the 2 pins.

4.1.9 Secure armature plate to bracket with the following included center-mounting bolt fasteners:

- Bolt with affixed rubber washer
- Steel washer
- Rubber washer
- Steel washer

NOTE: TIGHTEN CENTER-MOUNTING BOLT BUT, ALLOW FOR ARMATURE PLATE MOVEMENT AND ALIGNMENT.

NOTE: Apply thread locking compound to exposed thread.

Dimensions		
	EML310/320	EML371/372
A	7.48" [190]	7.24" [184]
B	0.06" [1.5]	0.06" [1.5]
C	0.38" [9.5]	0.38" [9.5]
D	2.61" [66.5]	1.63" [41.5]
1/2" model		
E	1.10" [28]	1.10" [28]
3/4" model		
F	1.36" [34.5]	1.36" [34.5]

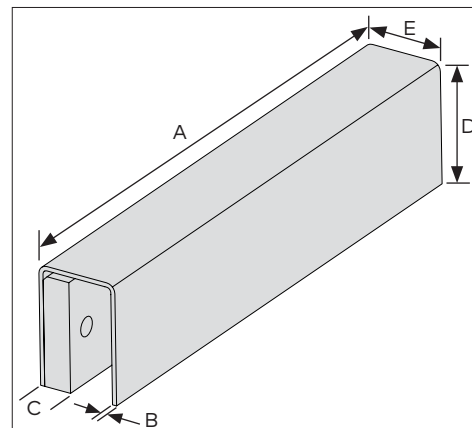

4.2 (For use with DRS rails only)

Fig. 12

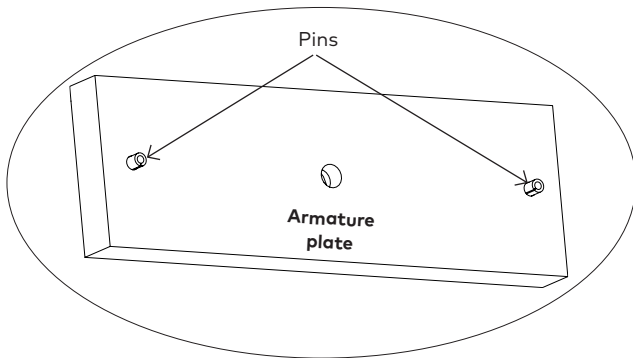

4.2.1 Align armature plate via the 2 pins.

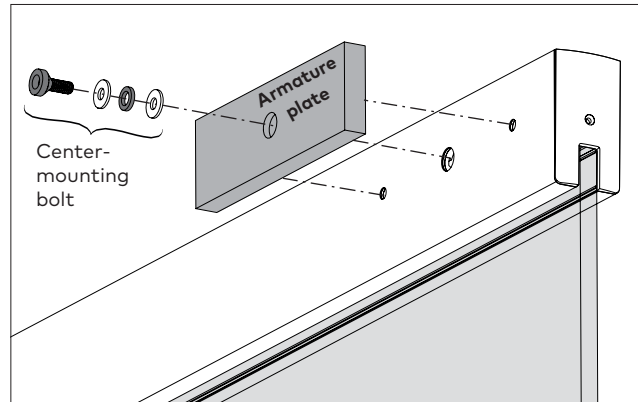

4.2.2 Secure armature plate to DRS rail with the following included center-mounting bolt fasteners:

- Bolt with affixed rubber washer
- Steel washer
- Rubber washer
- Steel washer

NOTE: Armature plate should remain movable. See step 4.2.3 on this page.

NOTE: Armature plate must be allowed to pivot on the center-mounting bolt to allow proper alignment with the magnet surface. If not properly aligned with the magnet surface, the lock may lose holding force or not lock at all.

NOTE: Apply thread locking compound to exposed thread.

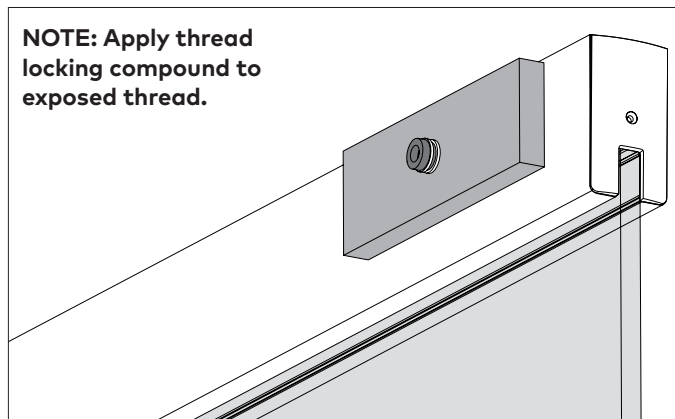

4.2.3 **NOTE: TIGHTEN CENTER-MOUNTING BOLT BUT, ALLOW FOR ARMATURE PLATE MOVEMENT AND ALIGNMENT.**

NOTE: The head of the armature mounting bolt ships with a rubber washer affixed to it. Ensure this washer projects slightly beyond the surface of to armature plate. This is to allow the washer to expand when power is removed and break the air vacuum between the plate and the magnet surface. **DO NOT REMOVE OR TRIM THE WASHER.** This will cause the lock to continually have some holding force even when power is removed.

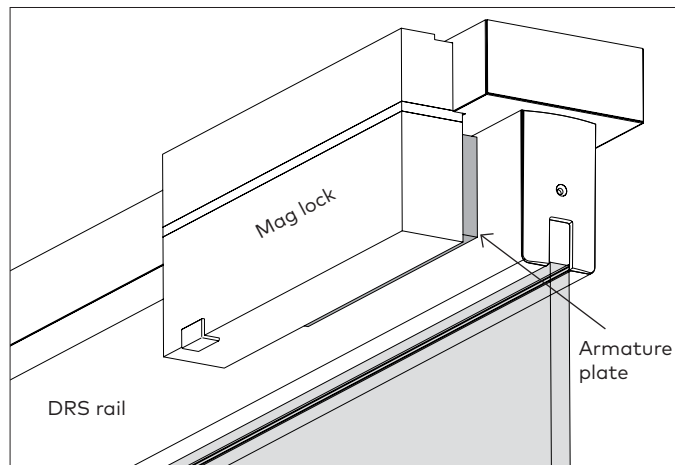

4.2.4 Close door and adjust armature plate if necessary.

5 EML310/320 and 371/372 Options

5.1 Instant release of lock

Fig. 13

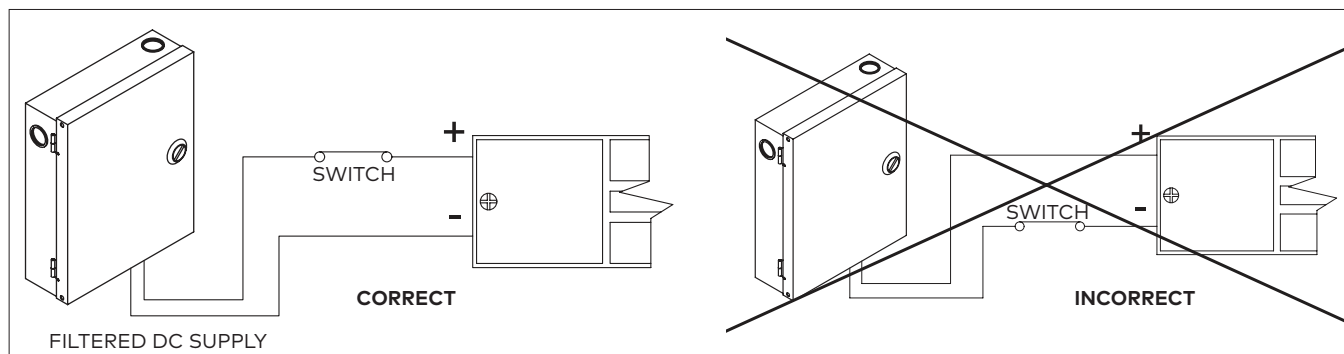

5.1.1 All switching devices must be wired between the DC power source and the positive terminal of the lock. See Figure above.

5.1.2 Switching the negative power supply line will NOT allow the lock to release immediately.

5.1.3 dormakaba electromagnetic locks contain TVS and MOV's for surge suppression.

- No other additional suppression is required to be added during installation.
- The installation of diodes across the lock input terminals will cause a delay in release.

5.2 Lock monitoring options - BA - Bond Alert Sensor

5.2.1 **Bond Alert Sensor** - detect locking bond quality between the surface of the magnet and armature plate.

- Sensitivity example: an object with a thickness of .007" [.2] is sufficient to allow the sensor to detect a problem.

NOTE: Surfaces must be kept free of contaminating materials.

NOTE: Lock surface and armature plate must be cleaned periodically with a non-abrasive cleanser.

NOTE: Armature plate and magnet must be properly aligned to ensure proper sensor function.

NOTE: Lock status is indicated via LED mounted on bottom of lock housing.

Green LED: door locked with secure bond.

Red LED: door unlocked or poor bond.

NOTE: *Security Condition Sensor* - available as factory ordered option only.

5.3 Lock monitoring options - DP - Door Position Sensor

5.3.1 **Door Position Sensor** - monitors the position of the door.

- The SPDT reed switch (mounted within the lock cavity) eliminates the need for extra sensors to be installed on the door for notification of security or access control systems.
- The DP option comes with a magnet pre-installed into the armature plate for signaling the reed switch in the housing when the door is closed.

NOTE: Ensure DP is operating correctly during final testing.

- **Availability** - The Door Position Sensor may be ordered as either a factory option or a field installed accessory.
- **Ordering** - When both the DP and TS are added together as a field accessory, they must be ordered as a combination to ensure proper fit.

6 Wiring the EML

6.1 Wiring mag lock body through header (for EML310/320 and 371/372)

Fig. 14

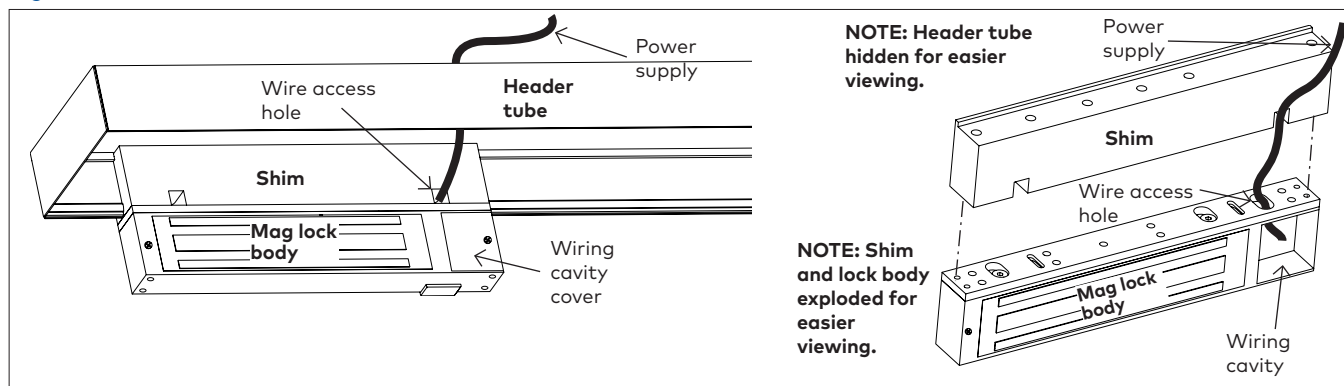

- 6.1.1 Remove wiring cavity cover.
- 6.1.2 Route the power supply connecting wire through the frame/header tube/shim (as necessary) and into the wire access hole.

NOTE: Power supply should be of sufficient gauge for the lock being installed and the distance being run. See Table 1 and 2 for reference.

Table 1 Wire gauge selections - load current at 24V

Total one way length of wire run (ft.)	Load current							
	1/4A	1/2A	3/4A	1A	1-1/4A	1-1/2A	2A	3A
100	20	18	16	16	14	14	12	10
150	20	16	14	14	12	12	10	--
200	18	16	14	12	12	10	10	--
250	18	14	12	12	10	10	--	--
300	16	14	12	10	10	--	--	--
400	16	12	10	10	--	--	--	--
500	14	12	10	--	--	--	--	--
750	12	--	--	--	--	--	--	--
1000	12	--	--	--	--	--	--	--

Table 2 Wire gauge selections - load current at 12V

Total one way length of wire run (ft.)	Load current					
	1/4A	1/2A	3/4A	1A	1-1/4A	1-1/2A
100	18	16	14	12	12	10
150	16	14	12	10	10	--
200	16	12	10	10	--	--
250	14	12	10	--	--	--
300	14	10	--	--	--	--
400	12	10	--	--	--	--
500	12	--	--	--	--	--
750	10	--	--	--	--	--

These recommended wire gauge selection tables are based on the 2008 National Electrical Code (2008 NEC), assume 140°F (60°C) rated wire, include a 25% safety factor, and define the amperage ratings at the listed distances that result in 5% voltage drop due to wire resistance. Five percent is normally acceptable in low voltage systems.

6.2 Wiring mag lock body (for EML310/320) - continued

Fig. 15

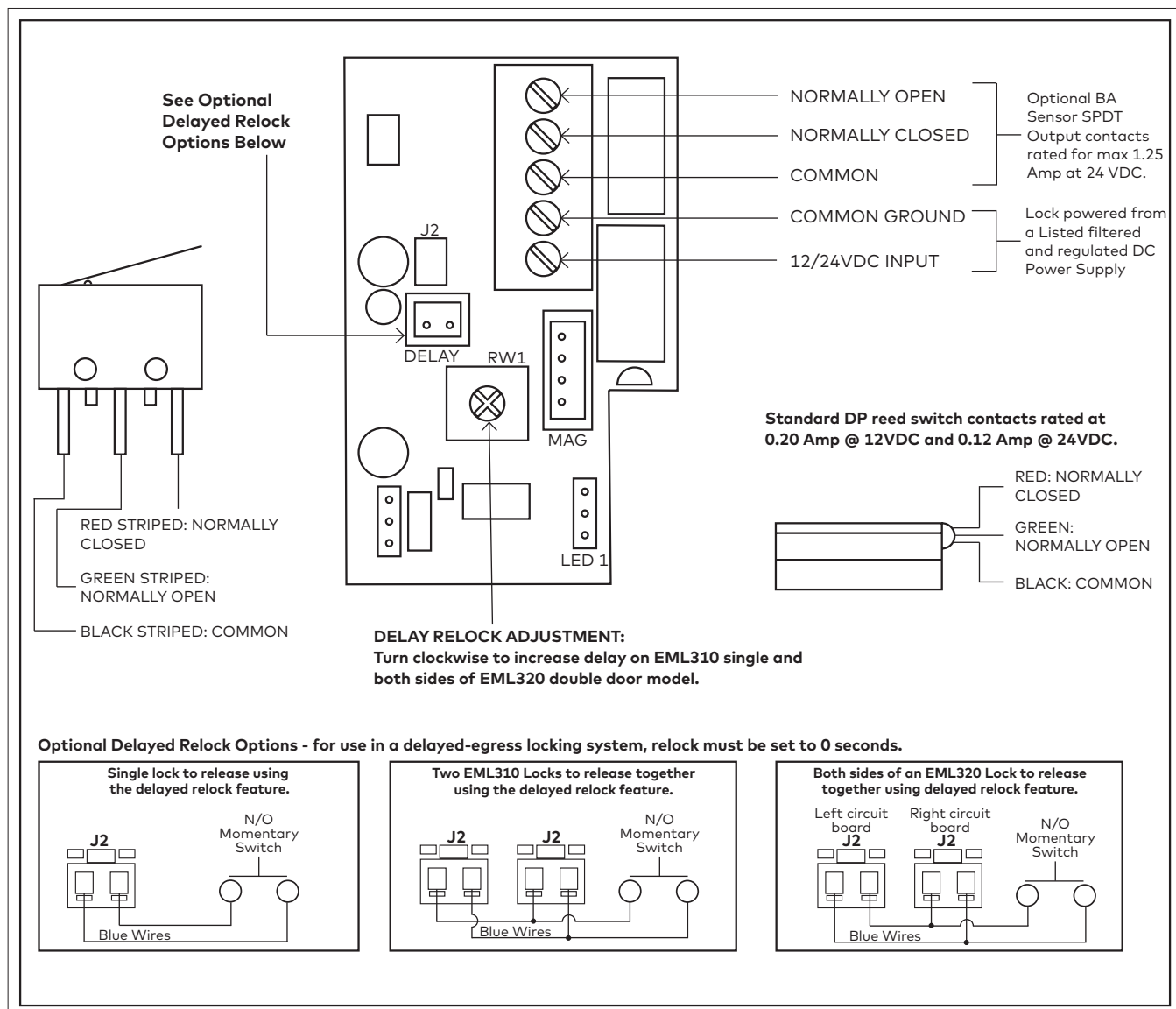

6.2.1 Connect wire to terminal blocks shown in Figure above.

6.2.2 If using [optional] **Bond Alert (BA)** and/or standard **Door Position Switch (DP)**: wire at this time as well. See Figure above.

6.2.3 Delayed Relock Feature:

- Used to momentarily release lock and keep it unlocked for a time period from 0 to 110 seconds.
- IF REQUIRED - Wire a Normally Open Momentary switch, such as Dorma 3909, to the two blue wires from J2 on the circuit board.
- IF NOT REQUIRED - The two blue wires must be unplugged from the circuit board at J2 to prevent possible lock malfunction.

6.2.4 Delayed Relock Time Delay Adjustment:

- Turn potentiometer (RW1) CLOCKWISE to increase delay time. (same for single or double doors)
- Factory setting is zero seconds.
- *If potentiometer (RW1) is not set at zero seconds, lock will enter delayed relock mode each time power is applied, even if J2 has been removed.*

6.3 Wiring for BA or BA DP combination models (for EML371/372)

Fig. 16

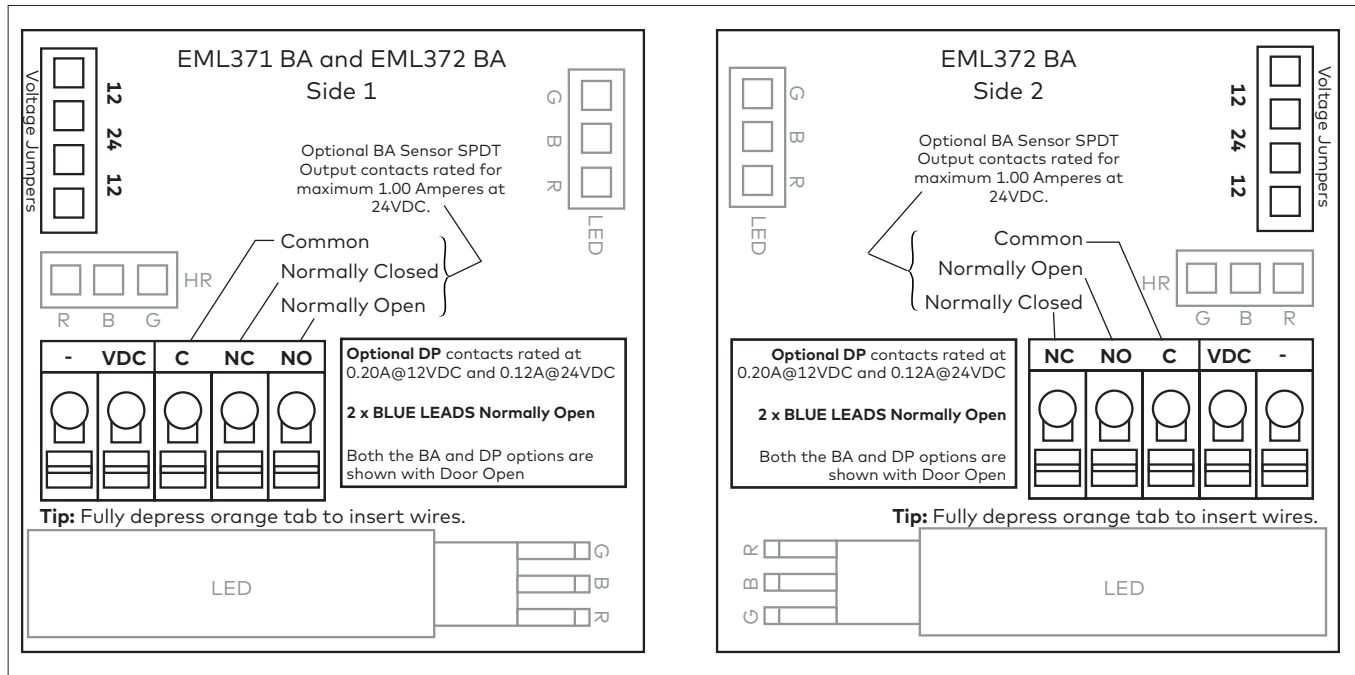

6.4 Wiring for Unmonitored or DP sensor models (for EML371/372)

Fig. 17

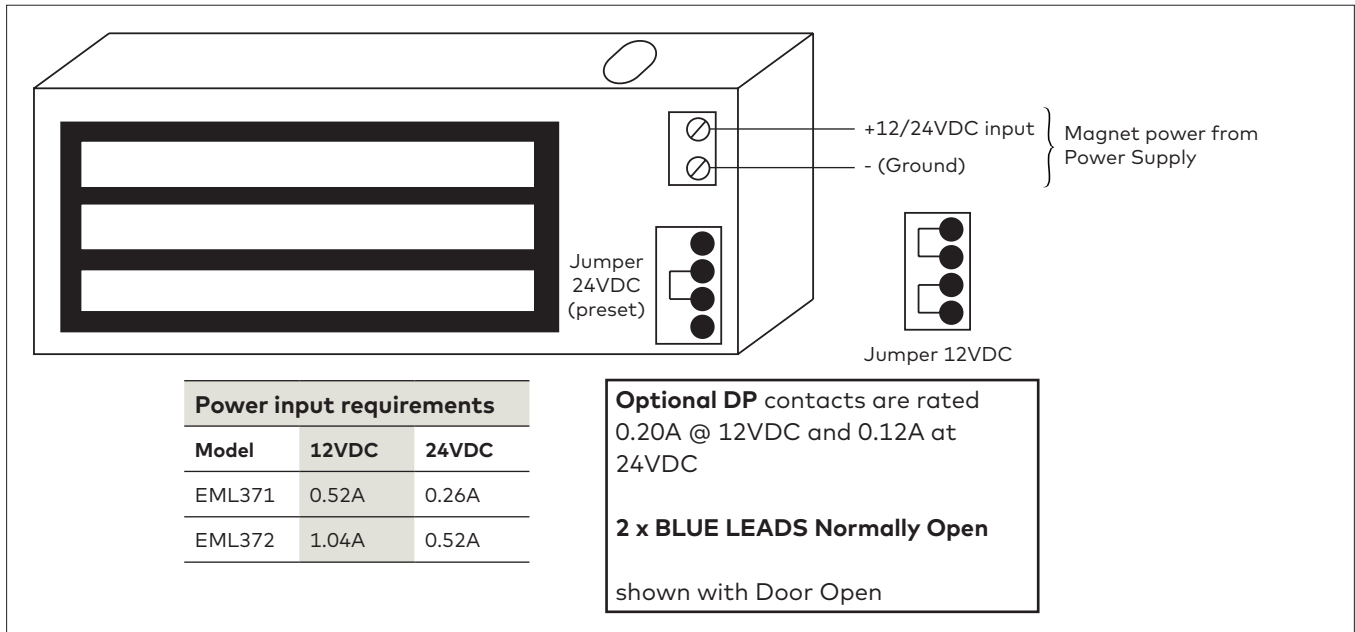

7 EML310/320 and 371/372 trouble shooting guide

Table 3

Problem	Solution
Cannot remove the lock mounting bracket from top of magnet for installation.	Remove anti-tamper screw and cavity screw. Insert supplied hex key into mounting bolt holes in the bottom of the lock housing and turn.
LED goes out when door is locked.	Check input polarity.
Lock is installed but has no holding force at all.	<ul style="list-style-type: none">• Check power supply. DC power should be slightly over the voltage specifications outlined on the packaging. (for example: for 12VDC operation supply should be set at 12VDC-13VDC.)• Check connections at power supply, connected releasing devices, lock terminals, and lock circuit board to magnet core.• Check delayed relock wiring and time setting.• Check that the momentary switch does not include a shunted light option.
Lock has enough holding force to lightly hold a screwdriver or set of pliers but door will not lock.	Check to see that armature plate is correctly aligned with the electromagnetic lock. If there is improper alignment, make a 1/4" turn of the armature plate mounting bolt and check for alignment. Make sure to follow the armature plate mounting instructions.
Lock is operating and locking but the armature plate is "humming" against the surface of the lock.	This generally indicates that the lock is either operating on AC voltage or there is AC voltage present in the DC supply. A properly filtered and regulated DC power supply is required to achieve optimal operation from the lock.
Lock is not releasing immediately upon removal of power.	<ul style="list-style-type: none">• Ensure that switching devices are interrupting the DC power and not the AC power supply voltage.• Ensure rubber washer on armature plate mounting bolt has not been removed or damaged.• Check that switching device interrupts the positive wire and not the negative wire.• Remove any diodes or other suppression devices that may be installed.

